



AUDITORIUM TECHNICAL SPECIFICATIONS

Below is some information around technical equipment and staffing at the Turner Centre.

HOUSE TECH & STAFFING

The Turner Centre requires you to always have a House Venue Technician when you use the Auditorium. This Venue Tech is able to operate basic sound, lighting and rigging pre-show.

If your show has a lighting programme or complex mixing needs, we recommend you have an additional technician to manage light or sound. If you do not have this person travelling for the show, then we can arrange this for an additional cost. Additionally, if you have rigging requirements (house curtains during show etc), that will require an additional trained person. Again, we can arrange this for an additional cost.

The Venue Tech hours in your Venue Hire Agreement are based on an estimate. Please note that you will be charged as per the actual hours required for your booking. If a specific set up is required before your arrival, this can be arranged with the venue technician prior to your arrival at an additional charge. A reset charge will also apply.

LIGHTING

TURNER CENTRE STAGE LIGHTING (Standard Light plan attached below)

- Hog 4 lighting console
- Five LX Bars @ 6.5m high
- Four-Colour Cyclorama Wash
- Follow Spot
- House-lighting: Dynalite wall racks, controlled from control room or onstage panels.
- 18 x CHAUVET Rogue R2X Wash LED moving wash heads
- 5 x CHAUVET Maverick 4.00 Force S Profile Moving heads, 350W led, 4.5-41.6 Units deg zoom with framing shutters.
- 8 x CHAUVET Ovation CYC3FC Low profile Cyc light, 1.2M long
- 3 x CHAUVET Maverick Force S Profile Moving head, 350W led, 4.5-41.6 deg zoom with framing shutters

GOBOS / IRISES - Included in Lighting

- 4x Apollo 1018-BS Foliage Break-up Close-up
- 1x Apollo 1027-BS Foliage Break-up
- 1x Apollo 1027-AR Foliage Break-up
- 2x Apollo 1000-BS Leaves
- 3x Rosco 238-232 Realistic Leaves
- 2x Rosco 238-277 Bare Branches 2
- 2x Rosco 805 Leaf Break-up (Medium)

SOUND EQUIPMENT

HOUSE AUDIO SYSTEM

- Soundcraft SI Impact Sound Board 32 channel
- FOH Speakers: 2 x EV full range 15' & horn 600 watts
- FOH Amp: 2 x LAB.GRUPPEN IP 2100 Amp
- Foldback Speakers: 3 x Australian monitor pro series 200 watts
- Foldback Amp: EV CP 1800 Amp
- Side Fills - 2 x EV Full range 12" & horn 300 watts
- Ring Delays - 1 x EV full range 15" & horn 600 watts
- Box ring delay - 2 x EV full range 12" & horn
- Centre fill - 1 x EV full range 15" & horn 300 watts
- XLR cables

Please note this house sound system is suitable for vocals and playback.

MICROPHONES & DIRECT INPUTS

- 10 x Sennheiser - radio mics & headsets
- 3 x Sennheiser Handheld Wireless Mics
- 2 x SM58 handheld mics
- 2 x Stereo Direct Inputs

UPGRADED PA SYSTEM

For bigger shows and live bands, we recommend hiring in a larger system. This can be arranged through the Turner Centre for a discount price through our preferred supplier, MMusic. This larger system suitable for bands includes:

- JBL three way tour rig and setup
- JBL SRX 835 Speakers
- PRX618 Sub
- JBL monitors
- Mics/stands/DIs/leads
- Individual components and backline can also be rented through MMusic. See prices below. Please contact MMusic directly regarding any technical questions and prices. Merv Pinny - 021 274 9553 or mmusic@outlook.co.nz

COMMS - Included with Auditorium hire

- Eartec UltraLITE HUB 7-Way System
- 7 radio headset units and one portable base unit

PROJECTOR -

- Full HD Panasonic PTRZ7750
- 7200 Lumens projector
- Maximum projected image 10m x 6m
- Cyclorama - 13.5m wide x 6.5m high

STAGE & STAGING

Auditorium stage dimensions: See floor plan attached.

Tri Deck Staging:

- 2 x Stage carriers
- 22 x Stage legs. 400mm

- 51 x Stage Legs 200mm
- 21 x Stage legs 600mm
- 21 x Stage legs 800mm
- 5 x Stage rails for 2 m
- 5 x Stage rails 1m
- 22 x Tri Deck Staging Units 1m x 2m

RIGGING - Included with Auditorium hire

- Counterweight Fly system
- If the cyc or house lights need to be moved before the show, this can be arranged with the venue technician prior to your arrival at an additional charge. A reset charge will also apply.

CURTAINS - Included with Auditorium hire

- Velvet Alicante House Curtain
- Velvet Alicante Valance
- 1 Set of Black Wool Serge Midstage Tabs
- 1 Set of Black Wool Serge Upstage Tabs
- 2 Sets (4 Curtains) Black Wool Serge Legs each 4.5 metres wide b 7.0 metre drop
- 2 Sets (4 Curtains) Black Wool Serge Legs each 3.0 metres wide x 7.0 metre drop
- 4 Black Wool Serge Borders
- 1 Pair Black Wool Serge Panorama Borders
- 1 Pair Black Wool Serge Tormentors
- Black Wool Serge teaser
- 1 x Black Sharkstooth Gauze CS Trevira Manufacture
- 1 x PVC Cyclorama

PIANO

- Steinway Grand piano
- Piano stool
- Price includes a piano tune

STAGE SURFACE

Sprung floor finished with Brush box timber stained dark. Painting of stage is not allowed.

LADDERS

- Aluminium ladder - 5m
- Aluminium ladder - 4m
- Aluminium ladder - 2.5m

AIRCON

Microclimate air conditioning system (displacement ventilation).

SEATING

- Total seating: 408
- Full size orchestra pit
- Raked seating
 - Stalls: 324 seats - this includes 32 seats in AABB*
 - Gallery: 2 x 34 seats = 68 seats
 - Boxes: 2 x 8 seats = 16 seats
 - 2 x wheelchair seats (Unless otherwise specified, we will remove 3 seats to allow for two wheelchair spaces, which will reduce the total capacity by one seat).
 - Front of House Sound mix Position – L15-L16 and K14-K16.
 - Turner Centre House Seats L3-L8.

* Please advise if you require AABB seating. These are removable and only available if the forestage is not in use and lowered.

See seating plan attached.

BACKSTAGE, GREEN ROOM & LOADING DOCK

CHANGING ROOMS

The changing rooms are located at stage level and comprise two general rooms each of 23.7m² with ensuite toilet/shower areas, together with two principal's changing rooms, both of which are ensuited.

Some basic garment racks, iron and ironing board are provided. On request, a garment steamer can be organised in advance.

For an additional charge, towels can also be organised in advance.

GREEN ROOM

The Green Room is located above the dressing rooms.

The Green Room has a kitchenette with jug, sink, fridge and microwave.

Coffee/tea/milk is included for commercial hirers.

LOADING DOCK

Backstage truck access

PA - Individual components and backline

Through MMusic

Description
Speakers PRX618 Sub
JBL SRX 835
Stage Box and Cat 5
JBL SRX 815 monitors
Speakers PRX615 Daily rate
Soundcraft 24
Lighting par can LED 180 w .X 12
Spot movers led 280w. Large X 2
LED 1000w Blinder / strobe
DI
Other Audio equipment on request
Back line amps - Fender deluxe reverb
Back line amps - Fender twin reverb
Back line amps - Amp 500 2 x 10"
Back line amps - Fender Rumber bass rig 2 x 10"
Back line amps - Marsh Plexi and cab

SEATING PLAN

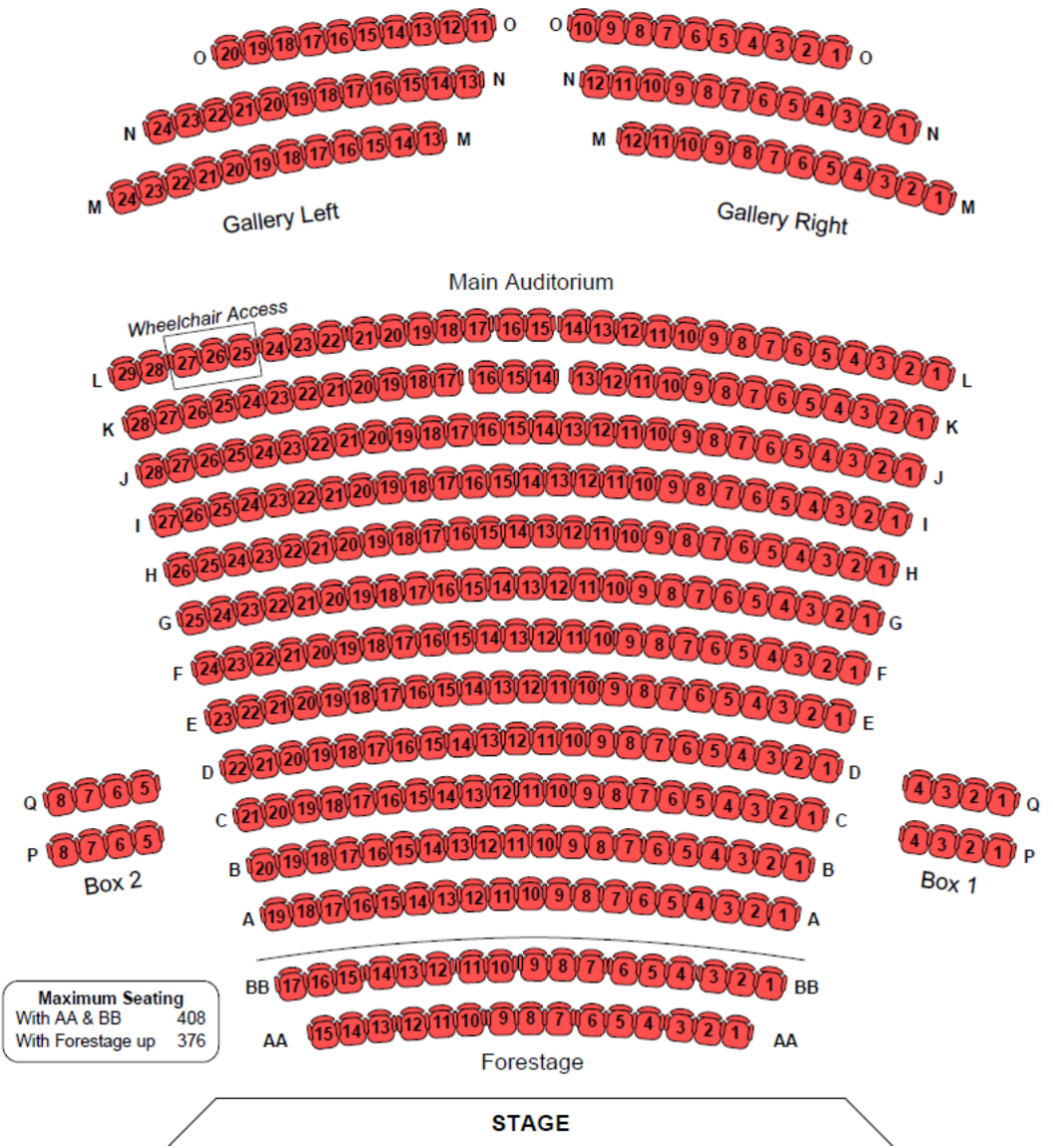

Auditorium Stage Top view



TURNER CENTRE
PERFORMING ARTS &
CONFERENCE VENUE
TE PUAWAI

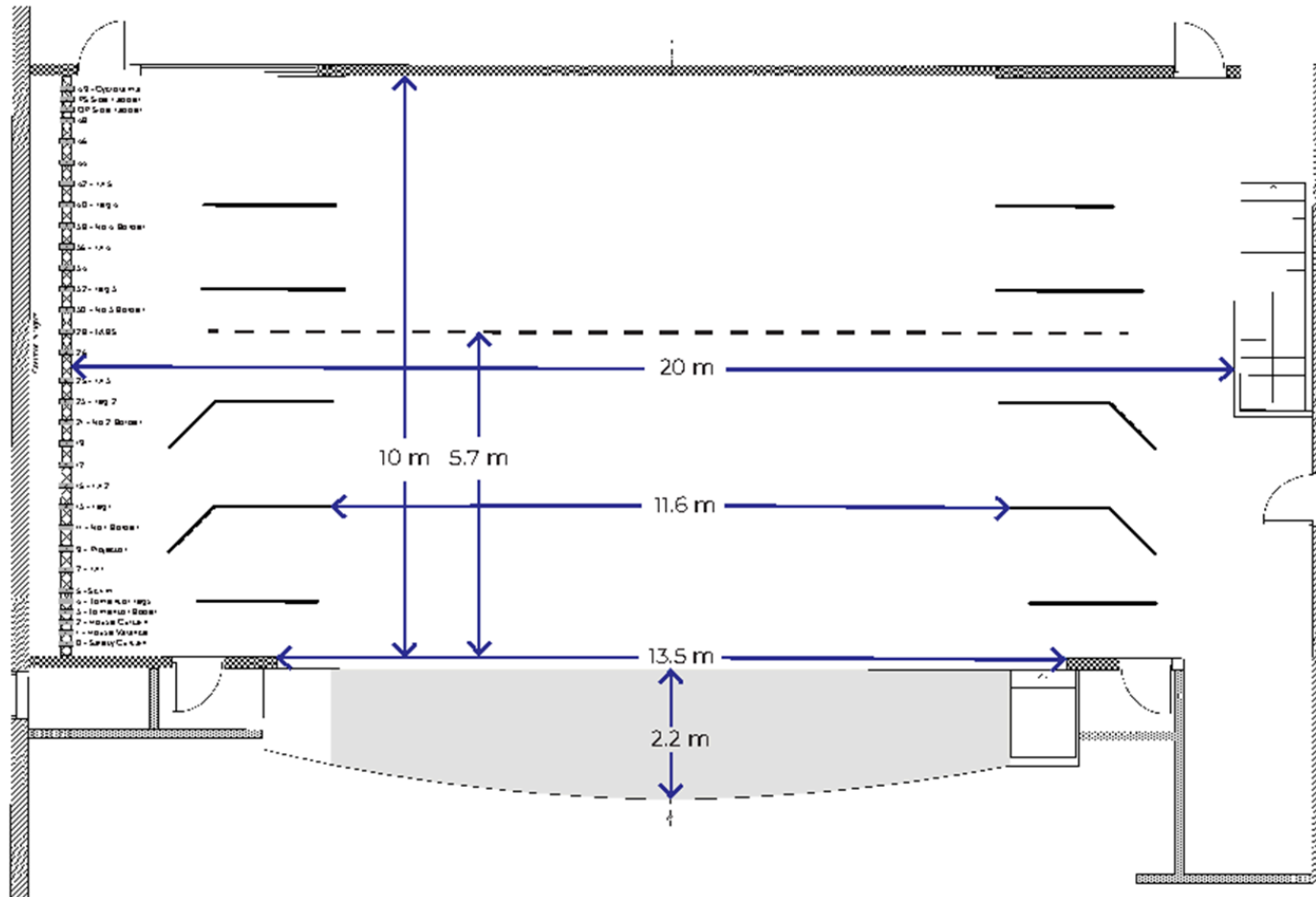

All care has been taken in producing this diagram however no responsibility is taken for its accuracy. It is presented for information only.

Auditorium Stage Front view



TURNER CENTRE
PERFORMING ARTS &
CONFERENCE VENUE
TE PUAWAI

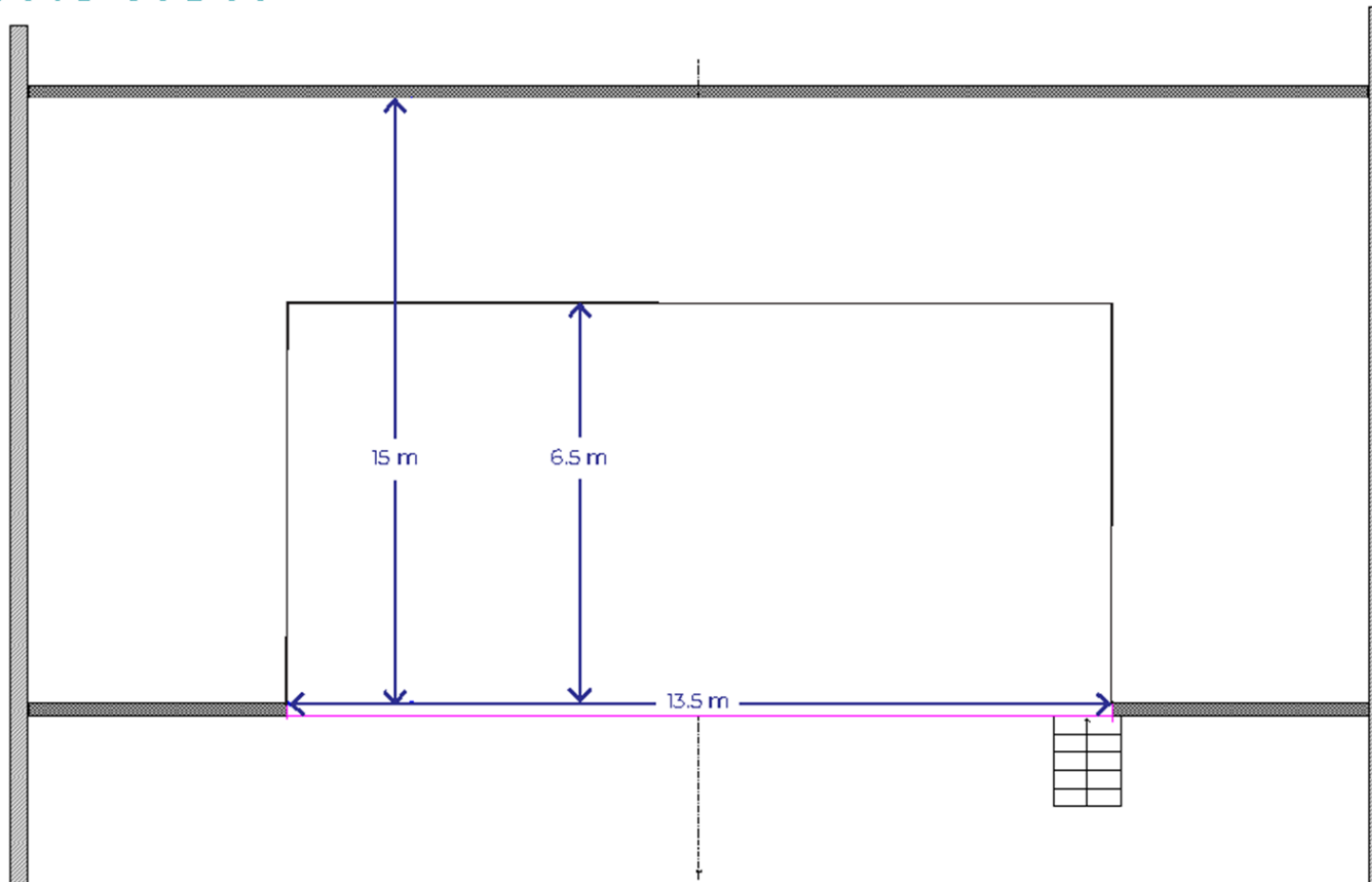

All care has been taken in producing this diagram however no responsibility is taken for its accuracy. It is presented for information only.





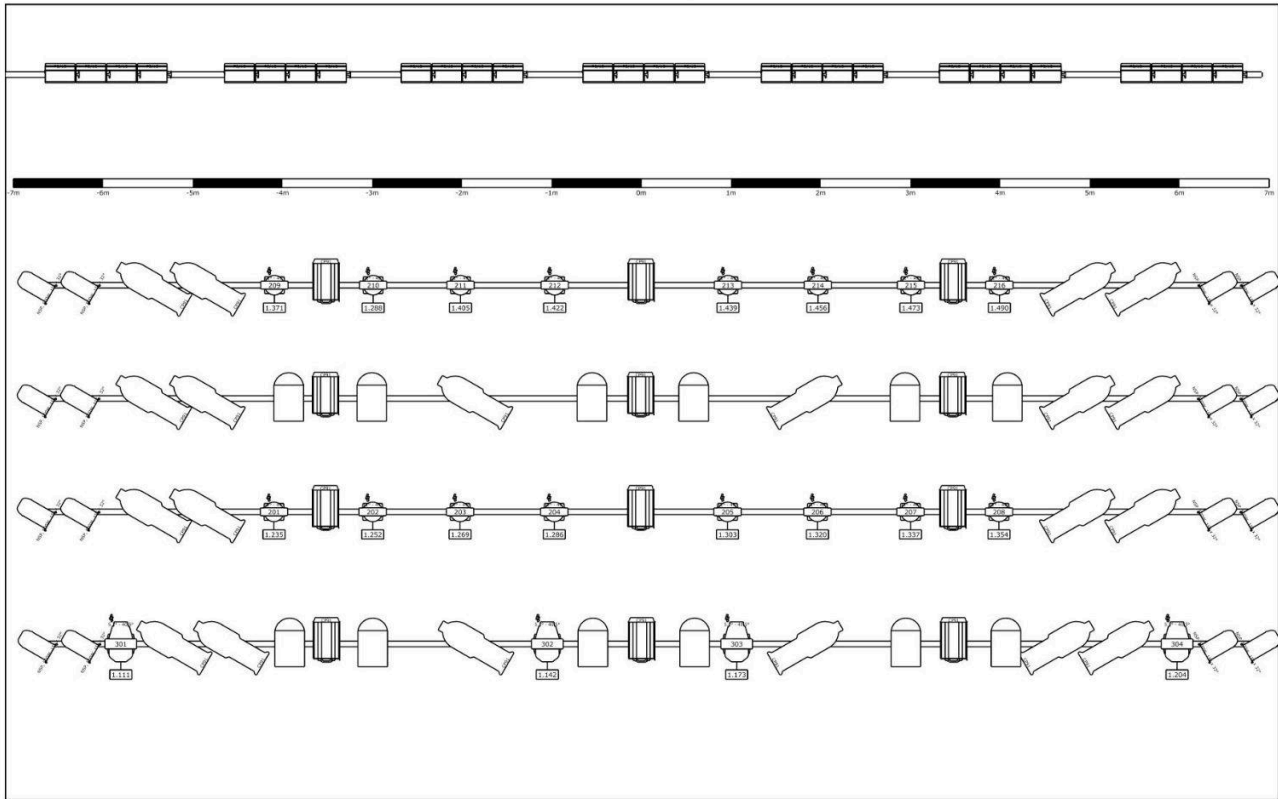

Project Lighting Upgrade 2024	 TURNER CENTRE PERFORMING ARTS & CONFERENCE VENUE TE PUAWAI
Project location	
Drawing author	



TURNER CENTRE
 PERFORMING ARTS &
 CONFERENCE VENUE
 TE PUAWAI



Symbol key

-  Aurora CYC (28)
-  Arena 14°-32° Zoomspot (20)
-  Rogue R2X Wash (16)
-  Par64 (16)
-  1200 Compact PC (12)
-  Arena PC (12)
-  Maverick Force S Profile (4)